

MEMPHIS NO. 7 MANHOLE RIM AND COVER, TENNESSEE NO. 3 MANHOLE CASTING WITH TYPE 'B' COVER.

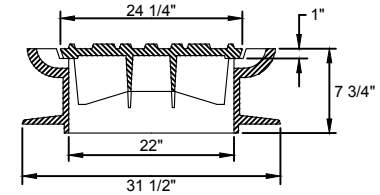

STANDARD MEMPHIS NO. 7
MANHOLE RIM AND COVER

N.T.S.

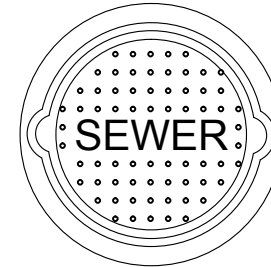
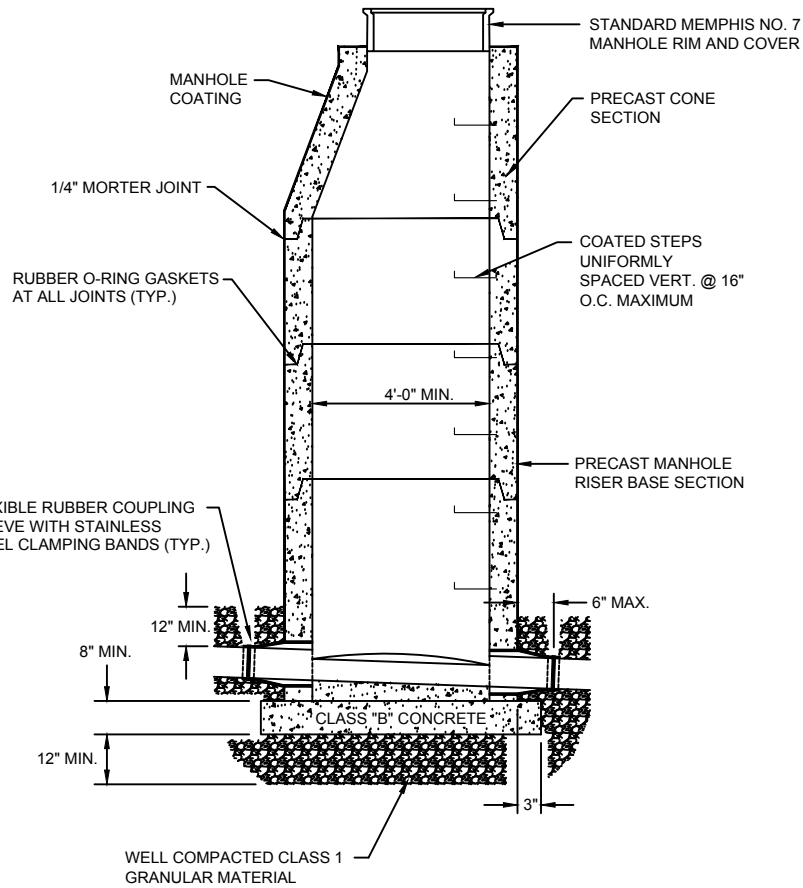

NOTE:

VACUUM TESTING FOR SEWER MANHOLES IS REQUIRED IN ACCORDANCE WITH ASTM C1244-93 AS DIRECTED BY THE COLLIERVILLE TOWN ENGINEER.

REVISION		
ITEM NO.	DESCRIPTION OF CHANGE	APPROVAL DATE

TOWN OF COLLIERVILLE
PRECAST SEWER MANHOLE
DETAIL

TOC-313