

"NAME OF FIRM" SHALL BE THE PERSON OR PERSONS RESPONSIBLE FOR THE FIELD LOCATION OF MARKER.

NOTE:

1. THE STANDARD CORNER/WITNESS DISK IS TO BE DRIVE ON A 4.0' #5 REINFORCEMENT STEEL BAR (REBAR). THE BAR ASSEMBLY IS TO BE DRIVEN INTO THE CENTER OF A 6" DIA. x 2'-6" DEEP HOLE. THE HOLE IS TO BE FILLED WITH 4,000 psi CONCRETE.
2. THE ACTUAL CONTROL POINT SHALL BE STAMPED ON THE DISK.

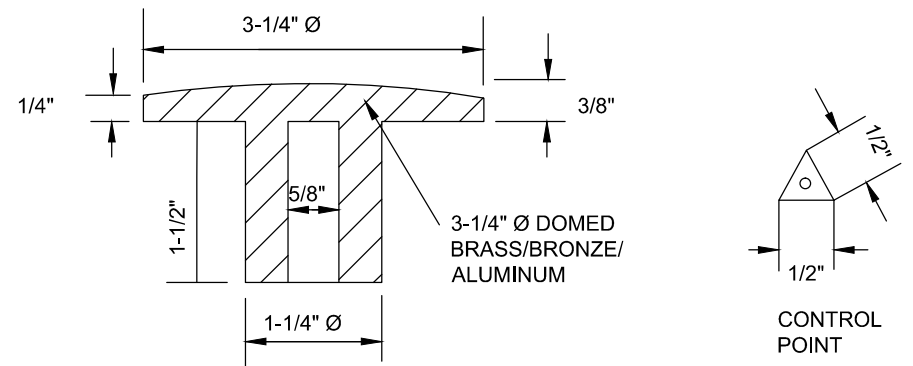

A-A STANDARD SUBDIVISION CORNER/WITNESS DISK CROSS-SECTION

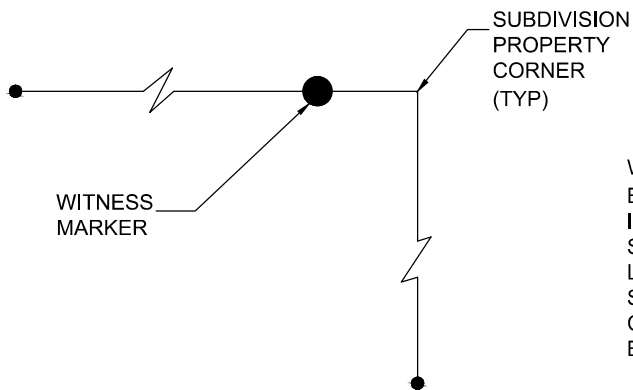

WITNESS MARKER IF NEEDED SHALL BE SET @ 10.0', 15.0' OR 20.0' EVEN INTERVALS ON LINE AND WILL BE SHOWN AND LABELED ON PLAT. THE LOCATION OF THE WITNESS MONUMENT SHALL BE BASED UPON FIELD CONDITIONS AND PLACED SO AS TO BE EASILY ACCESSIBLE.

REVISION		
ITEM NO.	DESCRIPTION OF CHANGE	APPROVAL DATE

TOWN OF COLLIERVILLE  
SUBDIVISION MONUMENT

TOC-101